

feltdecor[®]
s.line

More than silent

Product sheet
SilentScape

www.feltdecor.eu



SilentScape - Feltdecor® acoustic suspended systems

SilentScape combines a responsible approach to the environment with modern aesthetics. The suspended modules are made from PET felt recycled from plastic bottles, reducing waste and supporting a closed-loop economy. It's a solution that realistically fits into the idea of sustainable design and conscious material choices.

Functionality that serves comfort. With advanced acoustic properties, SilentScape effectively reduces reverberation and improves room sound quality. It is a dedicated solution for offices, hotels, commercial spaces and workplaces where acoustic comfort translates into the well-being and efficiency of users.

Design full of freedom and lightness. The modular design of SilentScape allows you to create individual compositions to match the scale and character of the interior. Elements can be freely combined to create unique patterns and configurations. An additional advantage of the collection is its light weight, which facilitates both transportation and quick installation, regardless of the chosen suspension system.

Choose SilentScape - the perfect solution for a space that inspires and delights.

Available colors: According to s.line color chart

Minimum order: One module

Mounting method: Screwed directly to the ceiling, suspended on cables

Cutting method: Perforation

Edge finishing: Straight cut

Module dimension: 1200x1200 mm, 2400x1200 mm

3D Models: Available from distributor

PET acoustic panels effectively absorb sound, creating a calm and quiet environment in any room. Whether it's an office, conference room, creative space or restaurant, our panels effectively reduce reverberation noise.

Sound absorption in a reverberation chamber according to PN-EN ISO 354:2005

Sample: Acoustic PET panels with a thickness of 9mm. Placed directly on the floor.

Sample area: 10,21 m²

Reverberation chamber volume: 200,00 m³

Reverberation chamber, with sample:

Temperature: 18,9 °C

Relative humidity: 43,8 %

Atmospheric pressure: 102,9 kPa

Reverberation chamber, empty:

Temperature: 18,9 °C

Relative humidity 47,2 %

Atmospheric pressure: 102,9 kPa

f [Hz]	T_1 [s]	T_2 [s]	A_T [m ²]	α_S	α_P
100	5,7	5,7	0,0	0,00	
125	5,9	5,9	0,0	0,00	0,00
160	4,9	5,0	0,0	0,00	
200	4,6	4,6	0,0	0,00	
250	4,4	4,2	0,3	0,03	0,05
315	4,6	4,3	0,6	0,06	
400	4,5	4,2	0,6	0,06	
500	4,8	4,0	1,4	0,13	0,15
630	4,5	3,5	2,1	0,20	
800	4,2	3,1	2,9	0,28	
1000	4,0	2,7	4,1	0,40	0,40
1250	3,8	2,4	4,9	0,48	
1600	3,6	2,2	6,0	0,59	
2000	3,4	1,9	7,0	0,69	0,70
2500	3,0	1,7	7,9	0,78	
3150	2,5	1,5	8,8	0,86	
4000	2,1	1,3	9,3	0,91	0,90
5000	1,7	1,1	9,6	0,94	

Indications:

f - frequency, in thirds bands [Hz]

T_1 - reverberation time of reverberation chamber, empty [s]

T_2 - reverberation time of reverberation chamber, with sample [s]

α_S - sound absorption coefficient

α_P - practical sound absorption coefficient

A_T - equivalent sound-absorbing area of the test sample [m²]

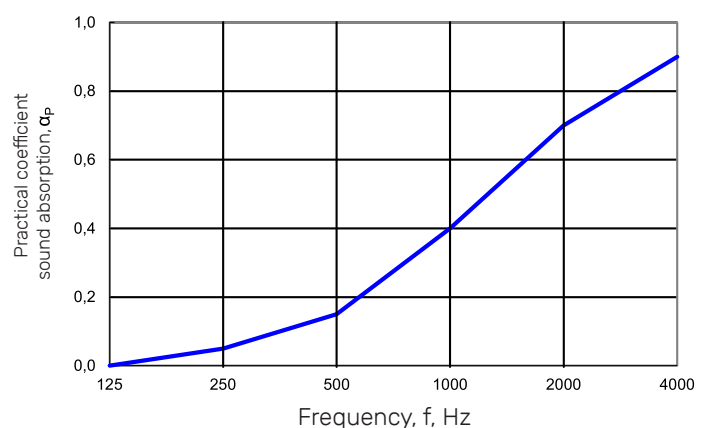
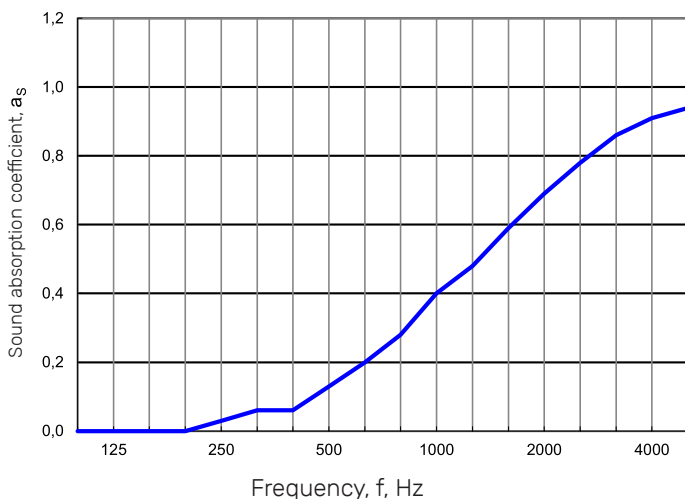

Sound absorption index and class according to PN-EN ISO 11654:1999

$\alpha_W = 0,25$ (H)

Sound absorption class: E

Sound absorption in a reverberation chamber according to PN-EN ISO 354:2005

Sample: Acoustic PET panels 9mm thick. Raised on the frame relative to the floor by 200mm ("air gap").

Sample area: 10,21 m²

Reverberation chamber volume: 200,00 m³

Reverberation chamber, with sample:

Temperature: 19,0 °C

Relative humidity: 45,2 %

Atmospheric pressure: 102,9 kPa

Reverberation chamber, empty:

Temperature: 19,0 °C

Relative humidity: 45,1 %

Atmospheric pressure: 102,9 kPa

f [Hz]	T_1 [s]	T_2 [s]	A_T [m ²]	α_s	α_p
100	5,5	4,7	1,0	0,10	0,30
125	5,3	3,2	4,0	0,39	
160	4,5	2,8	4,3	0,42	
200	4,5	2,6	5,3	0,52	0,65
250	4,4	2,3	6,8	0,67	
315	4,2	2,1	7,7	0,76	
400	4,3	2,1	7,8	0,77	
500	4,2	2,0	8,5	0,84	0,75
630	4,0	2,1	7,3	0,71	
800	3,7	2,1	6,4	0,63	
1000	3,4	2,0	6,7	0,65	0,65
1250	3,2	1,9	6,9	0,68	
1600	3,0	1,9	6,7	0,66	
2000	2,8	1,8	6,7	0,65	0,65
2500	2,5	1,6	7,1	0,69	
3150	2,1	1,4	7,3	0,71	
4000	1,7	1,2	7,4	0,73	0,75
5000	1,4	1,1	7,7	0,76	

Indications:

f - frequency, in thirds bands [Hz]

T_1 - reverberation time of reverberation chamber, empty [s]

T_2 - reverberation time of reverberation chamber, with sample [s]

α_s - sound absorption coefficient

α_p - practical sound absorption coefficient

A_T - equivalent sound-absorbing area of the test sample [m²]

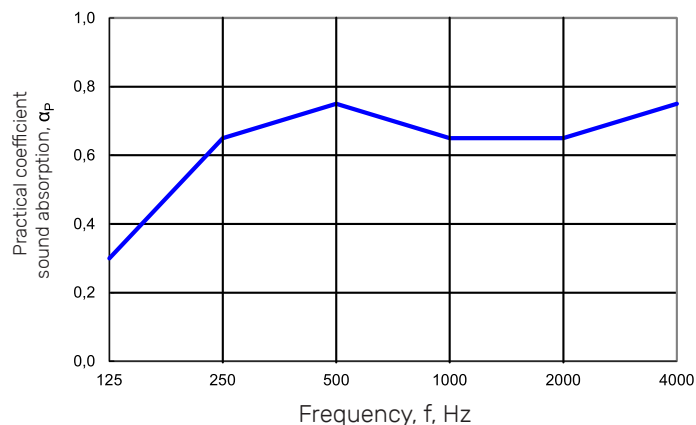
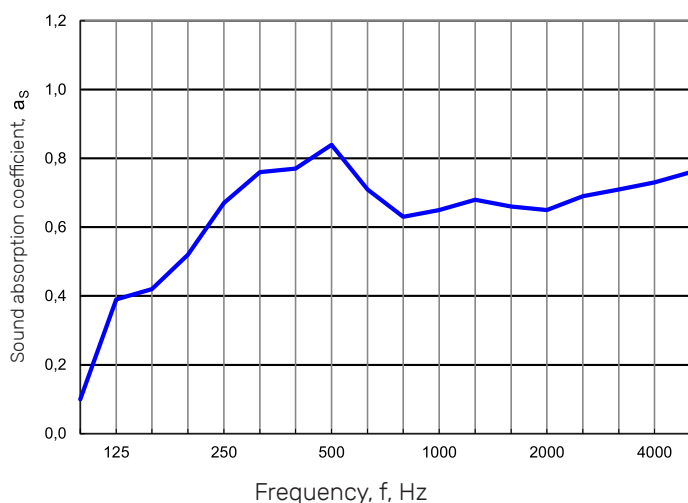

Sound absorption index and class according to PN-EN ISO 11654:1999

$\alpha_w = 0,70$

Sound absorption class: C

Sound absorption in a reverberation chamber according to PN-EN ISO 354:2005

Sample: Acoustic PET panels 9mm thick. Laid on a layer of 40mm thick basotec foam.

Sample area: 10,47 m²

Reverberation chamber volume: 200,00 m³

Reverberation chamber, with sample:

Temperature: 18,9 °C

Relative humidity: 44,5 %

Atmospheric pressure: 102,9 kPa

Reverberation chamber, empty:

Temperature: 18,9 °C

Relative humidity: 47,2 %

Atmospheric pressure: 102,9 kPa

f [Hz]	T_1 [s]	T_2 [s]	A_T [m ²]	α_s	α_p
100	5,7	4,8	1,0	0,09	0,30
125	5,9	3,8	3,1	0,30	
160	4,9	2,7	5,2	0,50	
200	4,6	2,4	6,4	0,61	0,75
250	4,4	2,1	7,9	0,75	
315	4,6	2,0	9,5	0,91	
400	4,5	1,9	9,7	0,93	1,00
500	4,8	1,8	10,9	1,04	
630	4,5	1,7	11,4	1,09	
800	4,2	1,7	11,6	1,11	1,00
1000	4,0	1,7	11,2	1,07	
1250	3,8	1,6	11,1	1,06	
1600	3,6	1,7	10,6	1,01	1,00
2000	3,4	1,6	10,5	1,00	
2500	3,0	1,5	10,7	1,02	
3150	2,5	1,4	10,3	0,98	1,00
4000	2,1	1,2	10,5	1,00	
5000	1,7	1,1	10,7	1,02	

Indications:

f - frequency, in thirds bands [Hz]

T_1 - reverberation time of reverberation chamber, empty [s]

T_2 - reverberation time of reverberation chamber, with sample [s]

α_s - sound absorption coefficient

α_p - practical sound absorption coefficient

A_T - equivalent sound-absorbing area of the test sample [m²]

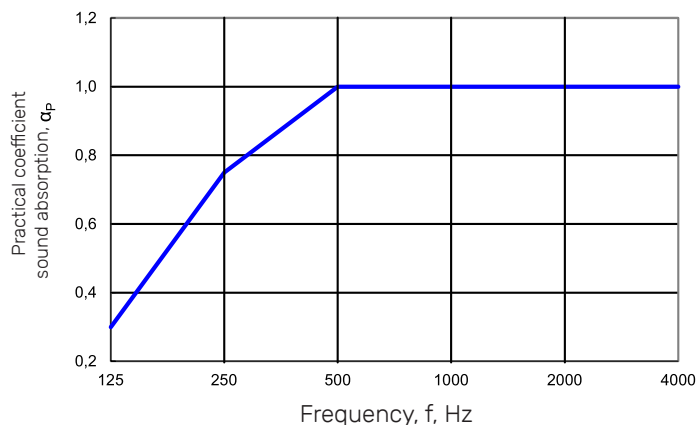
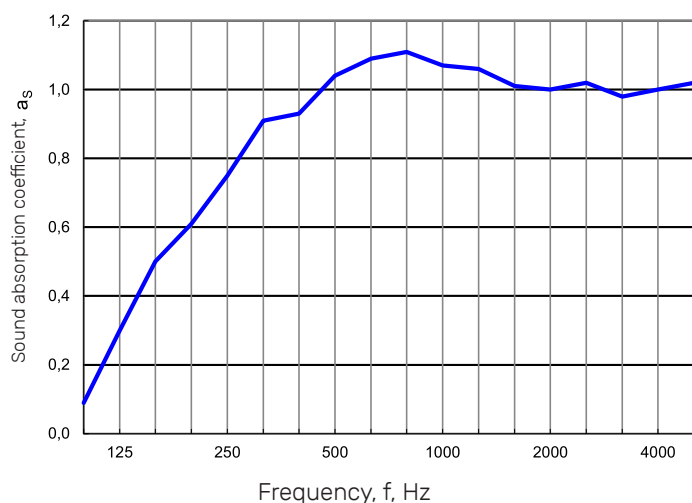

Sound absorption index and class according to PN-EN ISO 11654:1999

$\alpha_w = 1,00$

Sound absorption class: A

Color palette

Primary colors



FD10 / Wolf Grey

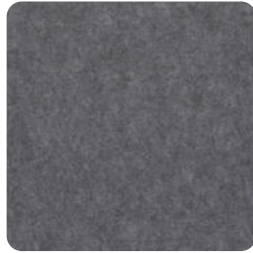

FD80 / Ash Grey



FD26 / Moonstone Grey



FD27 / Raven Black



FD25 / Onyx Grey

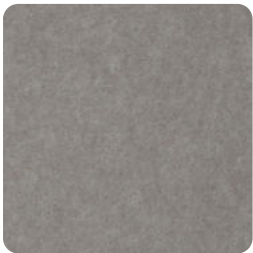

FD39 / Fallow Grey



FD06 / Desert Sand



FD05 / Sandy Beige



FD66 / Burly Wood



FD51 / Peru Brown

Thickness: +/- 9 mm | **Density:** 2000 g/m² | **Composition:** 100% PET polyester (partially recycled)
Sound absorption class: PN-EN ISO11654 $\alpha_w = 0,25$ for the product unassembled
Fire classification: EN 13501-1:2018 B-s1, d0 for all product applications

Slight differences in color and texture may occur with multiple orders.

Synthetic felt is a heterogeneous mixture of polyester fibers, so that slight differences in color are a natural characteristic of the material and are no reason for complaint.

The colors shown may vary depending on the characteristics of your screen - we recommend that you visit your dealer to make sure of your final color choice.

Color palette

Colors on request s.line 9mm - ask for availability



FD08 / Umber Brown



FD49 / Sunny Yellow

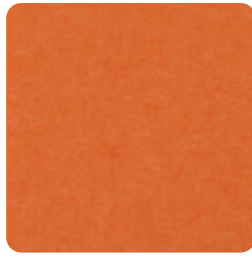

FD03 / Tangerine



FD17 / Poppy Red



FD18 / Crimson Mist



FD19 / Purple Rain



FD92 / Galactic Indigo



FD23 / Deep Sky Blue

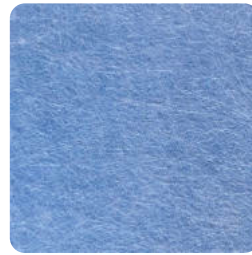

FD22 / Azure Blue



FD63 / Spring Sky



FD61 / Emerald Aurora

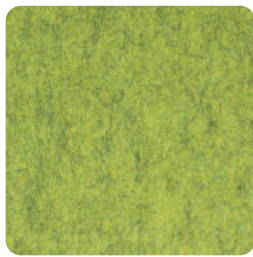

FD72 / Peridot Green



FD13 / Spring Green

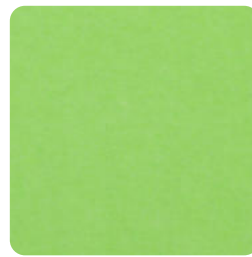

FD55 / Fresh Grass



FD04 / Moonlight

Thickness: +/- 9 mm | **Density:** 2000 g/m² | **Composition:** 100% PET polyester (partially recycled)
Sound absorption class: PN-EN ISO11654 $\alpha_w = 0,25$ for the product unassembled
Fire classification: EN 13501-1:2018 B-s1, d0 for all product applications

Slight differences in color and texture may occur with multiple orders.

Synthetic felt is a heterogeneous mixture of polyester fibers, so that slight differences in color are a natural characteristic of the material and are no reason for complaint.

The colors shown may vary depending on the characteristics of your screen - we recommend that you visit your dealer to make sure of your final color choice.

Color palette - UV printing

Only on FD05 / FD06 / FD10 / FD66



Classic Woodland



Beech Velvet



Dark Board



Darkwood Whispers



Driftwood Echo



Elder Wood



Oak Impressions



Rustic Grove



Vintage Timber



Walnut Heartwood



Woodland Charm



Woodland Harmony



Old Rust



Vintage Rust

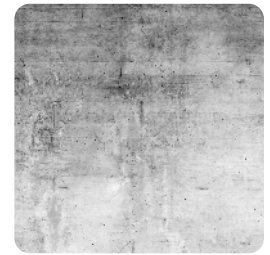

Concrete Mirage

Thickness: +/- 9 mm | **Density:** 2000 g/m² | **Composition:** 100% PET polyester (partially recycled)
Sound absorption class: PN-EN ISO11654 $\alpha_w = 0,25$ for the product unassembled
Fire classification: EN 13501-1:2018 B-s1, d0 for all product applications

Slight differences in color and texture may occur with multiple orders.

Synthetic felt is a heterogeneous mixture of polyester fibers, so that slight differences in color are a natural characteristic of the material and are no reason for complaint.

The colors shown may vary depending on the characteristics of your screen - we recommend that you visit your dealer to make sure of your final color choice.

Installation instructions - narrow rail

Cable suspended ceiling

1. Install 4 pieces of dowels with a hook in the previously prepared holes in the ceiling.

Hook the upper sling loops to the hooks.

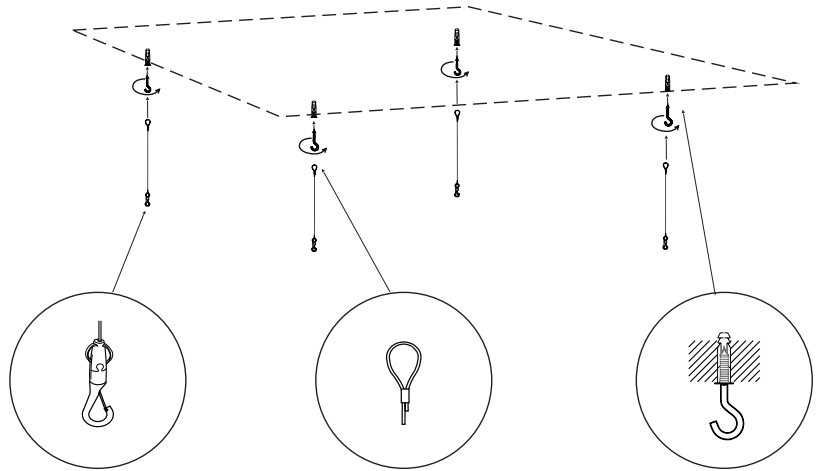
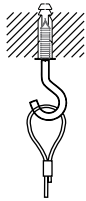

2. Slide the baffles into the slots located in the rails according to the diagram.

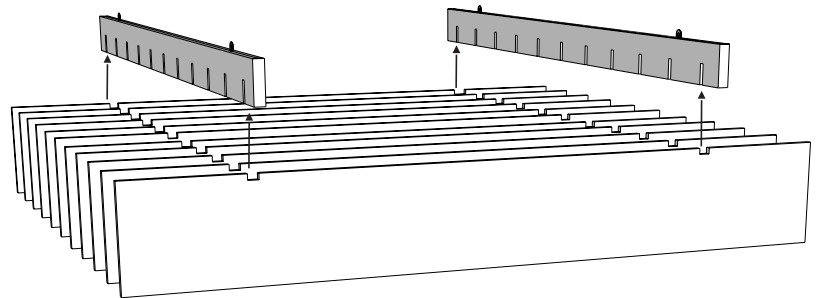

3. Mount the prepared module by hooking the carabiner to the hooks on the rail.

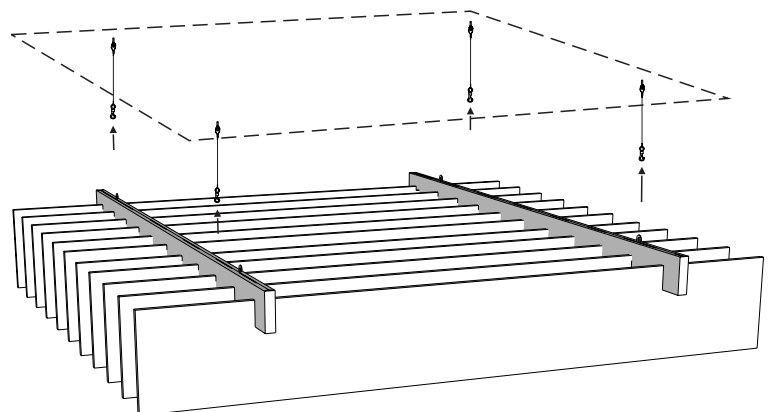
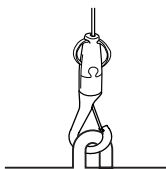

4. Adjust the height of the module suspension using the cable

Installation instructions - wide rail

Cable suspended ceiling

1. Install 4 pieces of dowels with a hook in the previously prepared holes in the ceiling.

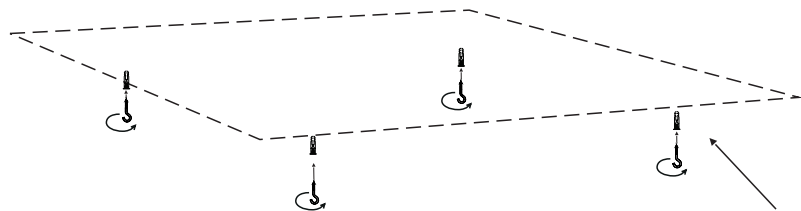

2. Screw the bracket to the rail.

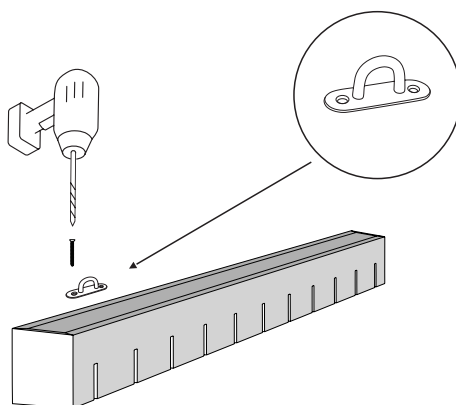

3. Slide the baffles into the slots located in the rails according to the diagram.

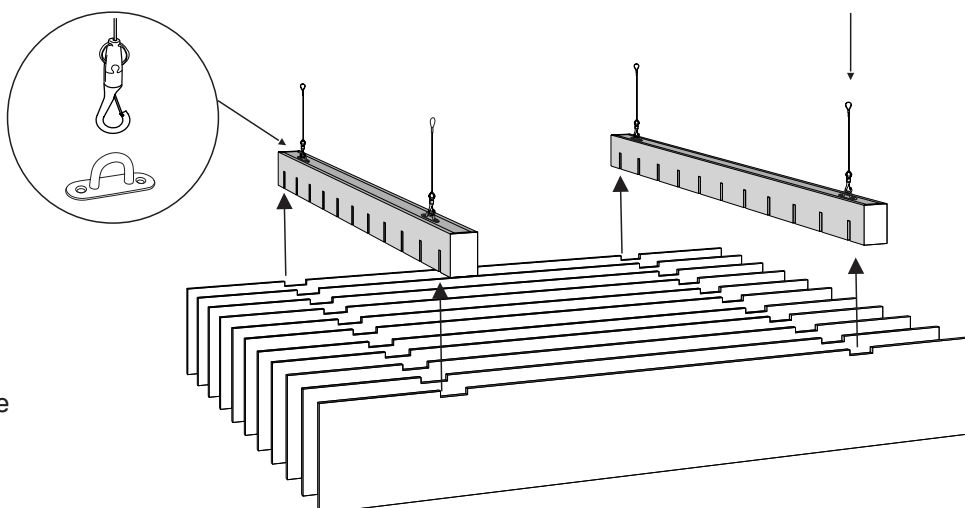

4. Put the carabiner of the mounting cable through the bracket in the rail, then hang the finished module on the previously prepared hooks.

1. Apply the rail to the wall or ceiling, then drill through the selected hole in the rail. Screw the rail to the wall or ceiling

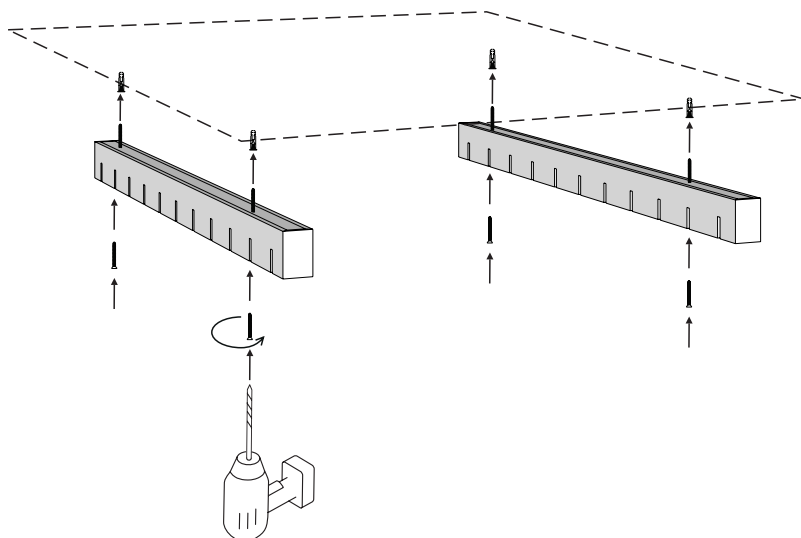

2. Slide the baffles into the slots located in the rails according to the diagram.

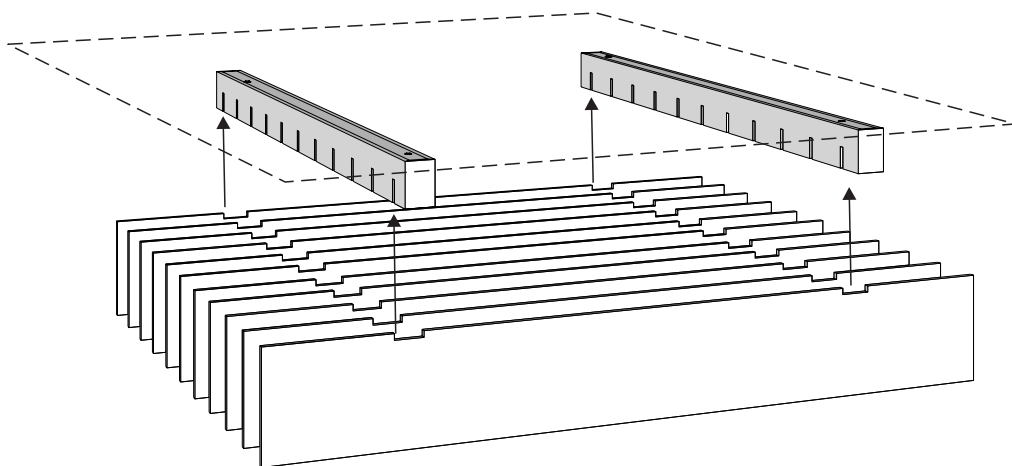

1. Use a dust broom or a vacuum cleaner with a soft suction nozzle to remove dust.

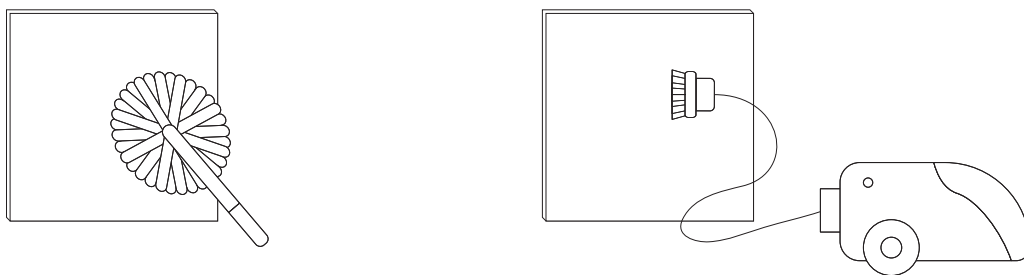

2. In the case of light contamination, wet the soiled area with water, then wipe lightly with a sponge and dry with a clean cloth. For medium contamination, apply a mild cleaner to the soiled area (we recommend testing in an invisible area).

If necessary, a steam cleaner can be used. **It is recommended to gently clean the panels without scrubbing.**

